

Duschtürband Farfalla *shower door hinge Farfalla*



- Duschtürband Farfalla/*shower door hinge Farfalla*
Anwendungsbeispiele/*applications*
Produktvorteile/*product benefits*
Einbausituationen/*location*
Produktinformationen/*product information*
techn. Information/*technical information*

● Farfalla

Farfalla ist im wahrsten Sinne des Wortes vielfältig

Diese Duschtürbänder sind universell einsetzbar, ob für Nischen-, Eck-, Rund- und U-Duschen – oder individuelle Badlösungen. Die Bandachse ist außerhalb der Glasflucht positioniert, so dass auch ein komplettes Falten der Glassegmente möglich ist. Bei einer Glashöhe von 1600 mm beträgt die maximale Ausladung 1400 mm.

Vorteile, die Sie und Ihre Kunden überzeugen:

- formschönes, ausgewogenes Design
- mehr als 50 Duschtürtypen möglich
- Duschtürdichtungen können durchlaufend, ohne Unterbrechung, verbaut werden

Farfalla offers manifold possibilities

These shower door hinges can be used for niche showers, corner showers, multiple sided showers, circular showers, U-showers and even bath tubs. The axis of the hinges is positioned outside of the glass axis which enables the glass panes to be folded together. Having a height of the glass panel of 1600mm, the maximum width is 1400mm.

Advantages that convince both you and your customer:

- aesthetic form and design
- possibility to construct more than 50 different types of shower doors
- the shower sealing can be installed without notching



● Farfalla



● Farfalla

Ein gutes Design überzeugt auch durch seine Funktion/ *An aesthetic design also convinces by the way it works*

Dass Farfalla gut aussieht, erschließt sich schon auf den ersten Blick. Aber auch bei genauerem Hinsehen weiß dieses Duschtürband zu überzeugen – mit ausgeklügelter Technik, hervorragender Qualität und praxisgerechten Details./ *You will realize at first sight that Farfalla is a looker. But if you have a closer look at it, you will be convinced by the sophisticated technology, the high quality and the practical details of this shower hinge.*

10



● Farfalla

Fakten/Facts

Funktion/Eigenschaft: Das Duschtürband ist ein einseitiges Anschlagtürband und daher ist die Montage mit einer durchgehenden Dichtung möglich. / *The shower door hinge is a one-sided striker shower hinge and therefore suitable for fittings with continuous sealing.*
Operating mode/Characteristic:

Vorteil/Advantage: Die Dichtung muß im Bandbereich nicht unterbrochen werden. Somit ist eine höhere Dichtigkeit der Dusche erreichbar. / *The sealing can be installed without notching, thus sealing the shower better.*
 - günstige Glasbearbeitung (nur Glasbohrungen erforderlich) / *Glass processing at a favourable price (only glass bores are needed)*

Zuhaltung/Closing mechanism: Die Zuhaltung wird durch Magnetdichtungen sichergestellt. / *Magnetic sealing profiles keep the door shut.*

Grundmaterial/basic material: Hochwertiger Zinkdruckguss von Pauli + Sohn durch langjährige Erfahrung in der Giess- und Oberflächentechnik:
 - Maßgenauigkeit durch Druckgusswerkzeuge
 - gleichbleibende Qualität
 - keine Fertigungstoleranzen
 - langjährige Erfahrung in der Oberflächenveredelung
High-quality zinc die cast by Pauli + Sohn having a long experience in casting and surface refinement:
 - *dimensional accuracy with die-casting tools*
 - *consistently good quality*
 - *no production tolerances*
 - *a long experience in surface refinement*

Oberfläche/Finishes: Glanzverchromt / *Bright chrome finish*
 Mattverchromt / *Matt chrome finish*
 Edelstahlfinish / *Stainless steel finish*
 (Edelstahlähnliche PVD-Beschichtung / *PVD coating similar to stainless steel*)

Tragfähigkeit/Load capacity: 40 kg entsprechen einem Glastürflügel von 1000 x 2000 mm bei einer Glasdicke von 8 mm /
40 kg corresponding to a glass door with the dimension 1000 x 2000mm and a glass pane thickness of 8 mm

Glasdicke/Glass thickness: 6-8 mm

Formgebung/Design: Hochkantformat-Formgebung in sich schlüssig und hochwertig / *an edgewise shape being conclusive and of high quality*

Anwendung/Application: Nischenduschen / *Niche showers*
 Eckduschen / *Corner showers*
 Rundduschen / *Circular showers*
 U-Duschen / *U-showers*
 Badewannenlösungen / *Bath tub solutions*
 Modulsysteme / *modular systems*

Zubehör + Extras/ Accessories + Extras: Dichtprofile, Duschköpfe und Griffe, Stabilisierungsstangen, Handtuchhalter
sealing profiles, door knobs and handles, supporters, towel bars

● Farfalla

Wählen Sie Ihre Einbausituation/*choose your location*

Das Design und die technische Finesse von Farfalla können Sie auf unterschiedlichste Art genießen, denn Farfalla passt sich diversen Einbausituationen flexibel an./*Benefit from the design and the technical refinement of Farfalla. It adapts flexibly to the different locations.*

Nischenduschen/*niche showers*



Set-3-101



Set-3-108



Set-3-102



Set-3-109



Set-3-103



Set-3-104



Set-3-105



Set-3-106



Set-3-107

Eckduschen/*corner showers*



Set-3-201



Set-3-202



Set-3-203



Set-3-206



Set-3-205



Set-3-208



Set-3-207



Set-3-211



Set-3-210



Set-3-204



Set-3-212



Set-3-209



Set-3-213



Set-3-214



Set-3-215



Set-3-216

● Farfalla

U-Duschen/U-showers



Set-3-403



Set-3-402



Set-3-404



Set-3-405



Set-3-406



Set-3-407

5-Eck-Duschen/5-corner showers



Set-3-301



Set-3-302



Set-3-303

Rundduschen/circular showers



Set-3-501



Set-3-502



Set-3-503

in Vorbereitung/in preparation

Badewannenlösungen/bath tub solutions



Set-3-612

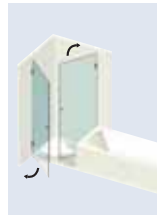

Set-3-611

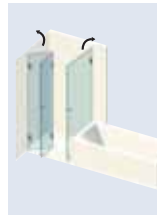

Set-3-609

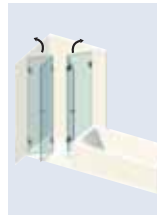

Set-3-610



Set-3-601



Set-3-607



Set-3-602



Set-3-608



Set-3-604



Set-3-603



Set-3-605



Set-3-613



Set-3-614



Set-3-606

Im Bereich der Faltbänder sollte das untere Wasserabweisprofil auf dem Wannenrand "auflaufen". Im geschlossenen Zustand ist, bedingt durch die Leichtigkeit unserer Bänder, zwischen den Türflügeln ein leichtes Einknicken nach Innen nicht auszuschließen.
 While using our folding door hinges, we recommend that the lower wipes have sufficient contact with the tub or shower basin to insure a fixed position of the door panels. Our hinges operate very lightly and need friction from the seals or wipes to remain stationary.

● Farfalla

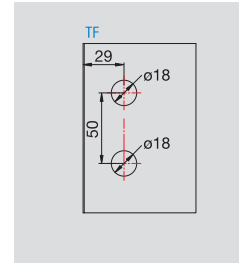
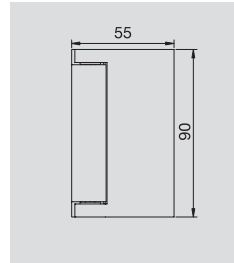
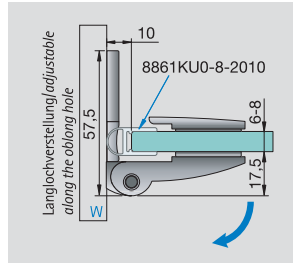
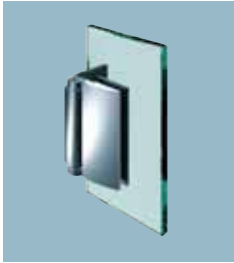

Artikel-Nr. Article-no.	Oberflächen Finishes	Artikelbezeichnung Article name	Glasdicke Glass thickness	Merkmale Features	VE/Stück pu/piece
8128	ZN5	Duschtürband, Glas-Wand 90°, 90° nach außen öffnend/ Shower door hinge, glass-wall 90°, only opening outward 90°	6-8 mm	Glasbohrung \varnothing 18 mm, Langlochverstellung/glass bore \varnothing 18 mm, adjustable along the oblong hole	1/2
	ZN1				
	ZNPVD22				

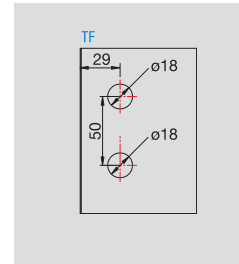
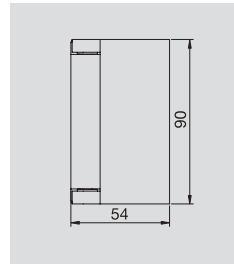
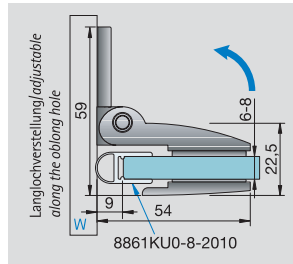

10

Artikel-Nr. Article-no.	Oberflächen Finishes	Artikelbezeichnung Article name	Glasdicke Glass thickness	Merkmale Features	VE/Stück pu/piece
8120	ZN5	Duschtürband, Glas-Wand 90°, 90° nach innen öffnend/ Shower door hinge, glass-wall 90°, only opening inward 90°	6-8 mm	Glasbohrung \varnothing 18 mm, Langlochverstellung/glass bore \varnothing 18 mm, adjustable along the oblong hole	1/2
	ZN1				
	ZNPVD22				

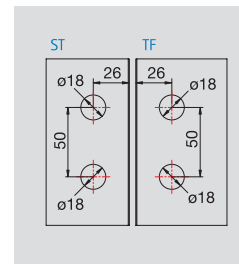
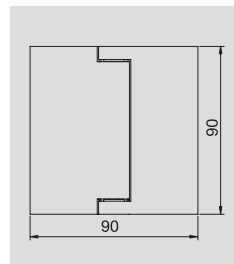
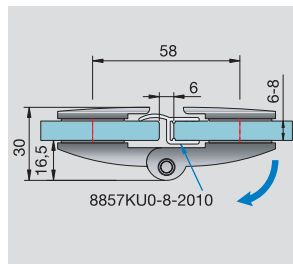

Artikel-Nr. Article-no.	Oberflächen Finishes	Artikelbezeichnung Article name	Glasdicke Glass thickness	Merkmale Features	VE/Stück pu/piece
8122	ZN5	Duschtürband, Glas-Glas 180°, 180° nach außen öffnend/ Shower door hinge, glass-glass 180°, only opening outward 180°	6-8 mm	Glasbohrung \varnothing 18 mm/ glass bore \varnothing 18 mm	1/2
	ZN1				
	ZNPVD22				

● Farfalla

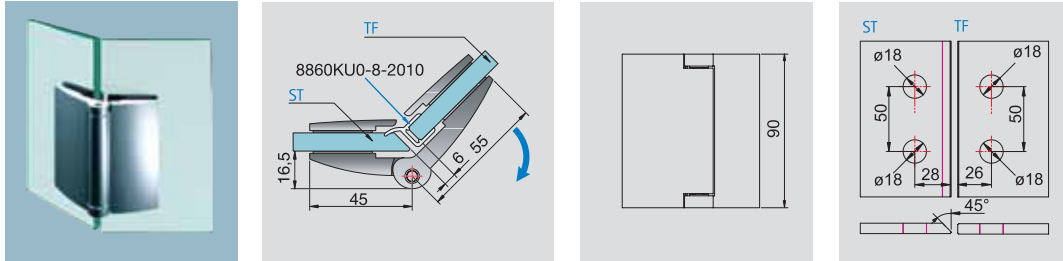

Artikel-Nr. Article-no.	Oberflächen Finishes	Artikelbezeichnung Article name	Glasdicke Glass thickness	Merkmale Features	VE/Stück pu/piece
8126	ZN5	Duschtürband, Glas-Glas 135°, 200° nach außen öffnend/ Shower door hinge, glass-glass 135°, only opening outward 200°	6-8 mm	Glasbohrung ø 18 mm/ glass bore ø 18 mm	1/2
	ZN1				
	ZNPVD22				

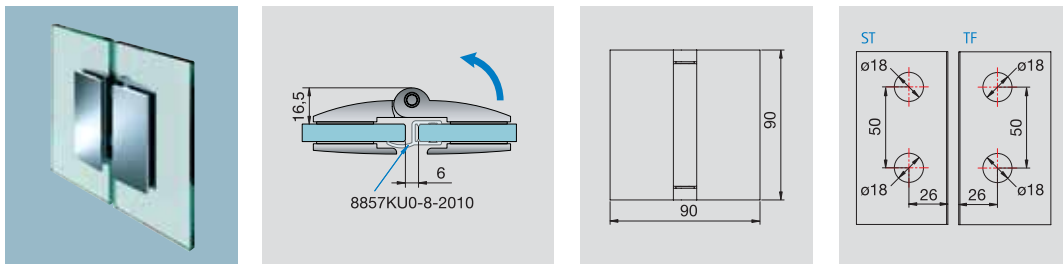

Artikel-Nr. Article-no.	Oberflächen Finishes	Artikelbezeichnung Article name	Glasdicke Glass thickness	Merkmale Features	VE/Stück pu/piece
8124	ZN5	Duschtürband, Glas-Glas 180°, 180° nach innen öffnend/ Shower door hinge, glass-glass 180°, only opening inward 180°	6-8 mm	Glasbohrung ø 18 mm/ glass bore ø 18 mm	1/2
	ZN1				
	ZNPVD22				

10

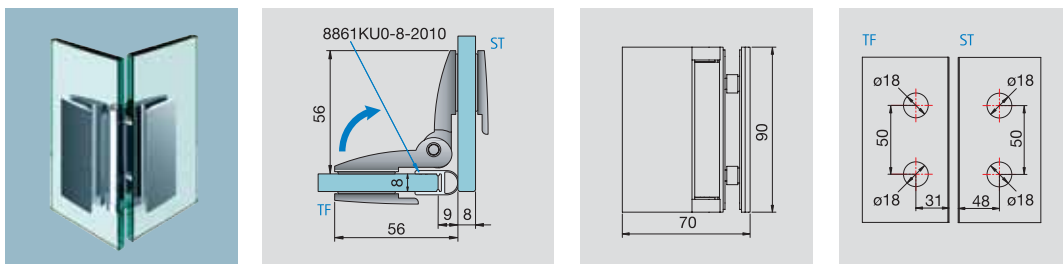

Artikel-Nr. Article-no.	Oberflächen Finishes	Artikelbezeichnung Article name	Glasdicke Glass thickness	Merkmale Features	VE/Stück pu/piece
8124	ZN5	Duschtürband, Glas-Glas 90°, 90° nach innen öffnend Shower door hinge, glass-glass 90°, only opening inward 90°	6-8 mm	Glasbohrung ø 18 mm/ glass bore ø 18 mm	1/2
	ZN1				
	ZNPVD22				

ST = Seitenteil/side panel
TF = Türflügel/wing of the door
W = Wand/wall

● Winkelverbinder/corner bracket

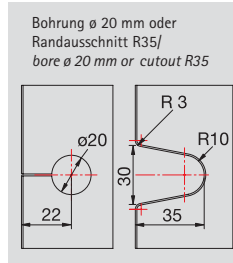
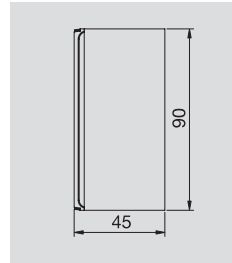
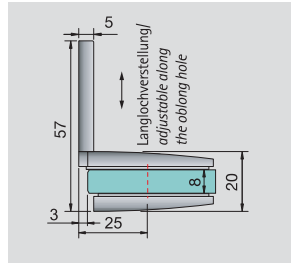

Artikel-Nr. Article-no.	Oberflächen Finishes	Artikelbezeichnung Article name	Glasdicke Glass thickness	Merkmale Features	VE/Stück pu/piece
8106	ZN5	Winkelverbinder, Glas-Wand 90° Corner bracket, glass-wall 90°	6-8 mm	Langlochverstellung/adjustable having an oblong hole	1/2
	ZN1				
	ZNPVD22				

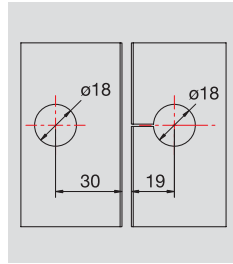
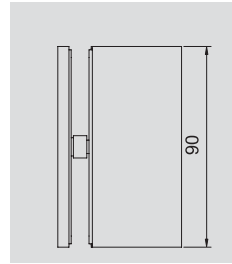
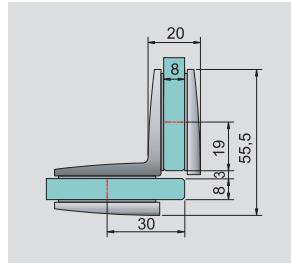

10

Artikel-Nr. Article-no.	Oberflächen Finishes	Artikelbezeichnung Article name	Glasdicke Glass thickness	Merkmale Features	VE/Stück pu/piece
8108	ZN5	Winkelverbinder, Glas-Glas 90° Corner bracket, glass-glass 90°	6-8 mm	-	1/2
	ZN1				
	ZNPVD22				

Farben/colours



ZN5 glanzverchromt/bright chrome finish



ZN1 mattverchromt/matt chrome finish



ZNPVD22 edelstahlfinish PVD-beschichtet/stainless steel finish PVD coated

● Farfalla-Einbausituationen/Farfalla locations

Technische Informationen für Anwendungsbeispiele/
technical information for applications example







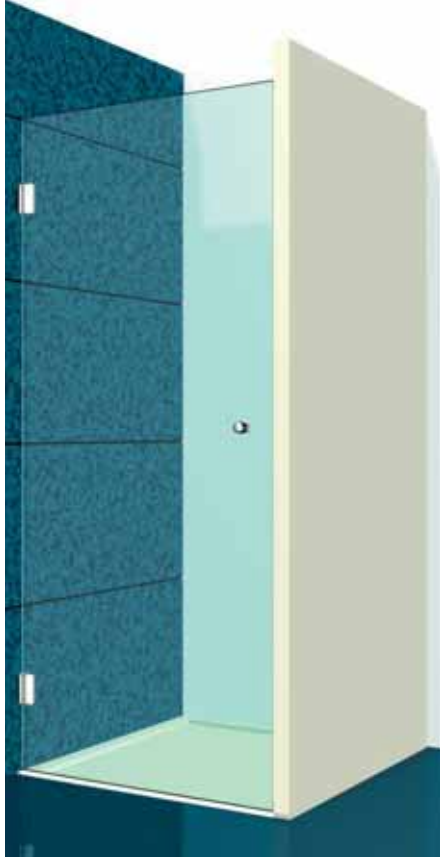

Farfalla - Nischendusche/ niche shower

10



Set 3-101

Nischenduschen Set bestehend aus/
niche shower set comprised of:

	2x 8128ZN		1 x 8851KU0-8-2010
	1 x 8298MS		1 x 8880-2010
	1 x 8861KU0-8-2010		
	1 x 8863KU0-8-2010		

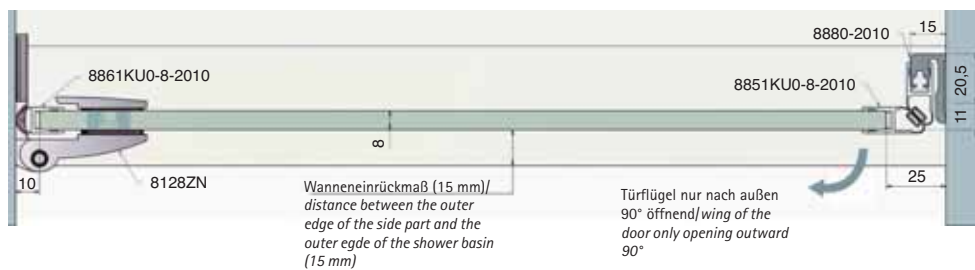
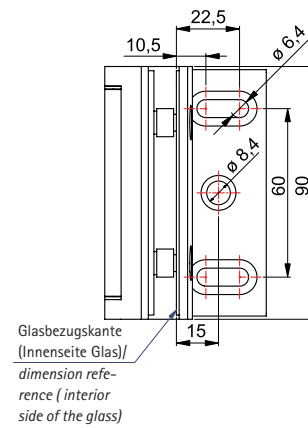
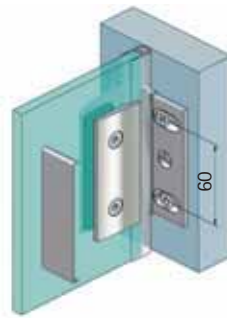



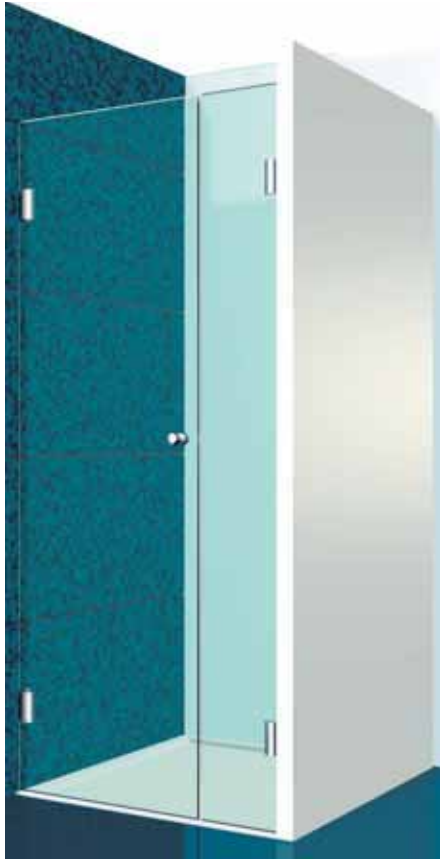



● Farfalla - Nischendusche/ niche shower



Set 3-102

Nischenduschen Set bestehend aus/
niche shower set comprised of:

	2x 8120ZN		1 x 8852KU0-8-2010
	2x 8106ZN		1 x 8863KU0-8-2010
	1 x 8298MS		
	1 x 8861KU0-8-2010		

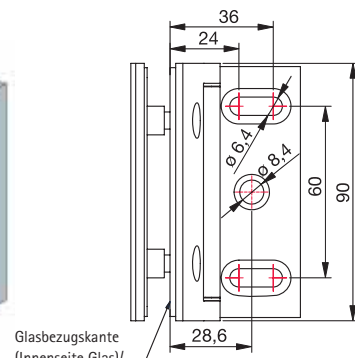
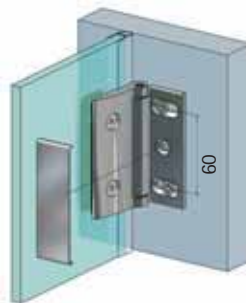

Glasbezugs-kante
(Innenseite Glas)/
dimension refe-
rence (interior
side of the glass)



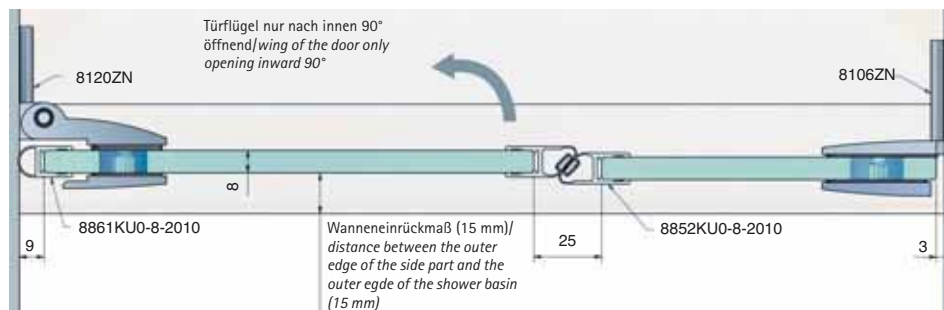



10



● Farfalla - Eckdusche/ corner shower

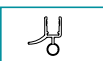

10

Set 3-210			
Eckduschen Set bestehend aus/ corner shower set comprised of:			
	2x 8122ZN		1 x 8857KU0-8-2010
	4 x 8106ZN		1 x 8851KU0-8-2010
	1 x 8298MS		1 x 8863KU0-8-2010
	1 x 8432MS-860		





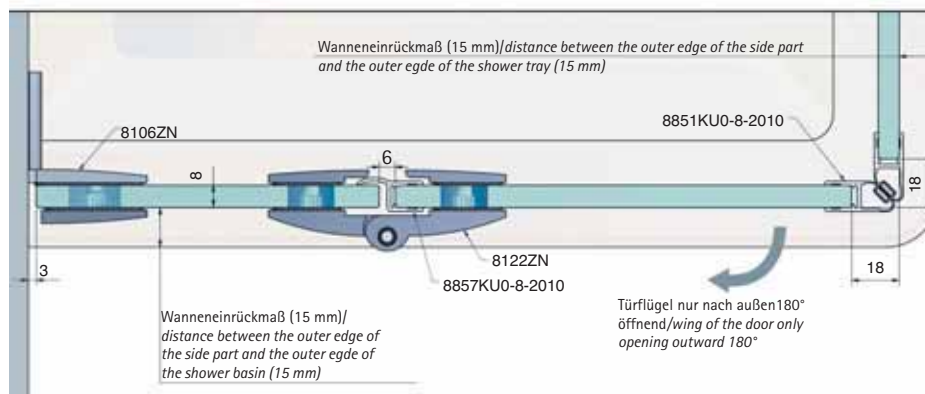



8122



● Farfalla - Eckdusche/ corner shower

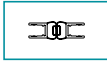

Set 3-211			
Eckduschen Set bestehend aus/ corner shower set comprised of:			
	2x 8120ZN		1 x 8432MS-860
	2x 8124ZN		2 x 8861KU0-8-2010
	2x 8106ZN		1 x 8850KU0-8-2010
	2 x 8298MS		1 x 8863KU0-8-2010

8124 - 90°

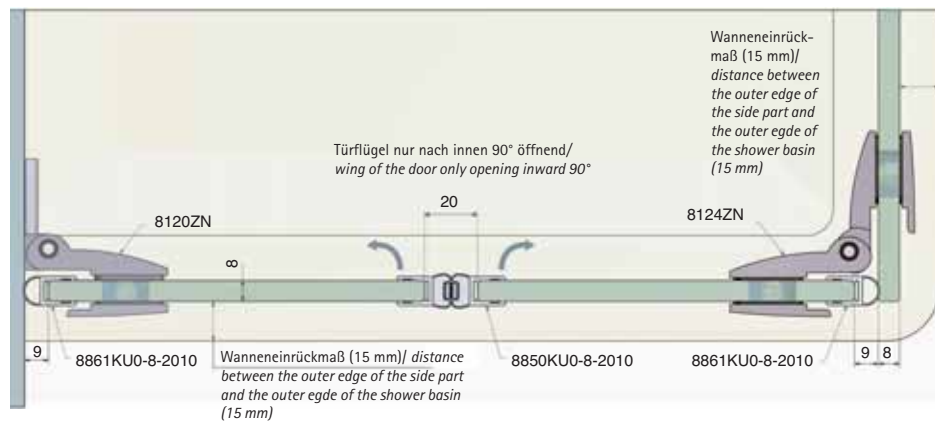







● Farfalla – Eckdusche/ corner shower

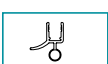

Set 3-212

Eckduschen Set bestehend aus/
corner shower set comprised of:

	2x 8122ZN		1 x 8852KU0-8-2010
	4 x 8106ZN		1 x 8857KU0-8-2010
	1 x 8298MS		1 x 8863KU0-8-2010
	1 x 8432MS-590		



gebogenes Seitenteil mit 2 Bohrungen/
bent side part with 2 bore
Art-Nr.: 8140-1Glas-R98
Glasmaße siehe Seite 622/
glass dimension page 622

Toleranzen/tolerance:

- Maßtoleranzen = $\pm 2/-2$ mm je laufender Meter/
dimension tolerances = $\pm 2/-2$ mm per running meter
- Versatz (Verwindung) = max. $\pm 3/-3$ mm je laufender Meter/
backfill (twisting) = max. $\pm 3/-3$ mm per running meter
- Durchbiegung der Höhenkanten = max. $\pm 3/-3$ mm je laufender Meter/
Height of edge deflection = max. $\pm 3/-3$ mm per running meter
- Abweichung der Konturtreue = max. $\pm 3/-3$ mm je laufender Meter/
Deviation from contour exactness = max. $\pm 3/-3$ mm per running meter
- Aufwölbungen im Bereich der Abwicklungskanten möglich/
Bulges in edge developing zone are possible.

10

Anisotropien/anisotropy : Anisotropien entstehen bei Glas, das einem thermischen Vorspannprozess unterzogen wurde. Durch die unterschiedlichen Spannungszonen entsteht eine Doppelbrechung der Lichtstrahlen. Nur die polarisierten Anteile des Tageslichtes machen diese Erscheinung durch spektralfarbene Ringe, Wolkenbilder und ähnliches sichtbar. Diese Erscheinungen sind produktionsbedingt und kein Reklamationsgrund. / Anisotropy occurs during the thermal tempering process of glass. Different tension zones lead to the diffusion of light beams. Only the polarized parts of the sunlight make spectral colored rings, cloud images and similar visible. These appearances are due to the production process and are therefore not a reason for rejection or complaint.

8140-1Glas-R98

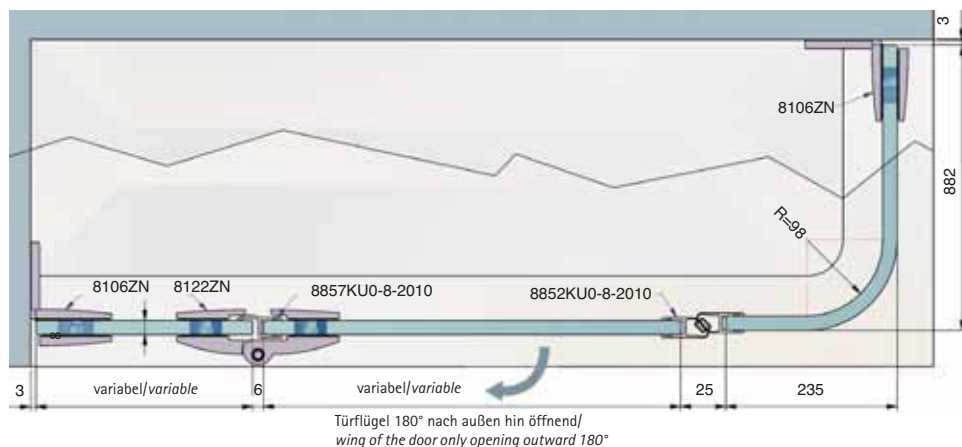

Farfalla 5-Eckdusche/ 5-corner shower



Set 3-301

5-Eckduschen Set bestehend aus/
5-corner shower set comprised of:

	4x 8106ZN		1 x 8860KU0-8-2010
	2 x 8126ZN		1 x 8853KU0-8-2010
	1 x 8298MS		1 x 8863KU0-8-2010
	1 x 8434MS-840		

Folgende Abzugsmaße müssen von der Duschtassenschenkellänge abgezogen werden, um das lichte Maß für die unterschiedlichen Wanneneinrückmaße zu erhalten./The following dimensions must be subtracted in order to obtain the clearance dimension for different basin offsets (glass - basin edge)

Einrückmaß basin offset	Abzugsmaß für lichtes Maß Türflügel subtraction for clear- ance dimensions (door)	Abzugsmaß für liches Maß Seitenteil/ subtraction for clearance dimensions (side panel)
0 mm	0 mm	0 mm
5 mm	4 mm	2 mm
10 mm	8 mm	4 mm
15 mm	12 mm	6 mm
20 mm	16 mm	8 mm

10

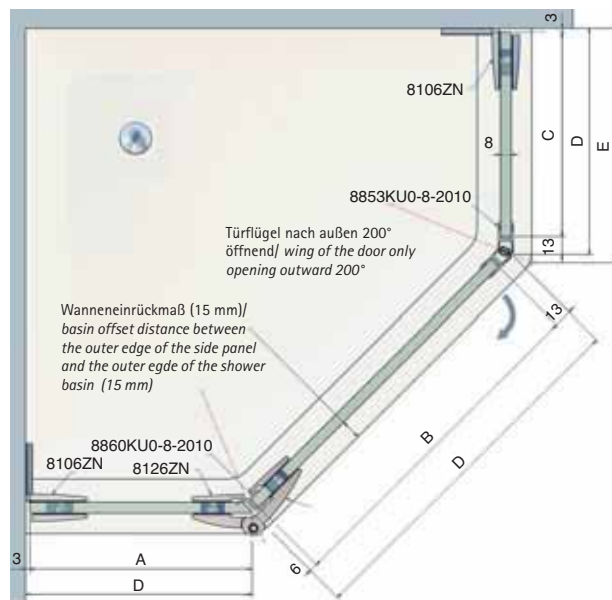

A = Glasmaß = liches Maß - 3/ glass dimensions = clearance dimensions - 3

B = Glasmaß = liches Maß - (6 + 13)/ glass dimensions = clearance dimensions - (6 + 13)





C = Glasmaß = liches Maß - (3+13) glass dimensions = clearance dimensions - (3 + 13)

D = Lichtes Maß/clearance dimensions

E = Schenkellänge Duschtasse/ shank length shower basin

● Farfalla – Badewannenlösung/ bath tub solution

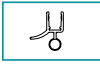

Set 3-602			
Badewannenlösung Set bestehend aus/ bath tub solution set comprised of:			
	2x 8120ZN		1 x 8857KU0-8-2010
	2 x 8122ZN		1 x 8863KU0-8-2010
	1 x 8298MS		
	1 x 8861KU0-8-2010		

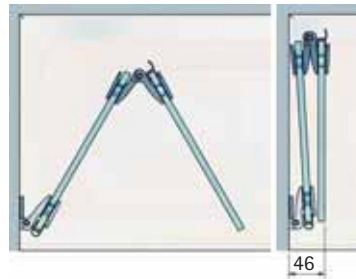

Die maximale Größe der Badewannenfaltwand beträgt 1400mm x 1600mm./The maximum size for the complete folding door for a bath tub is 1400mm x 1600mm.

10

Im Bereich der Faltbänder sollte das untere Wasserabweisprofil auf dem Wannrand "auflaufen". Da im geschlossenen Zustand, bedingt durch die Leichtigkeit unserer Bänder, zwischen den Türflügeln ein leichtes Einknicken nach Innen nicht auszuschließen ist./While using our folding door hinges, we recommend that the lower wipes have sufficient contact with the tub or shower basin to insure a fixed position of the door panels. Our hinges operate very lightly and need friction from the seals or wipes to remain stationary.





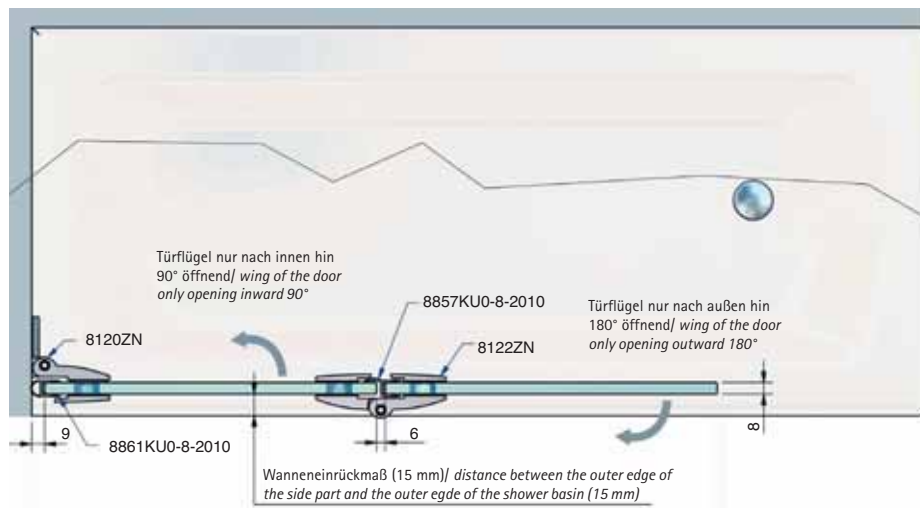

8122



Farfalla - Badewannenlösung/ bath tub solution

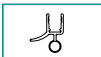

Set 3-608			
Badewannenlösung Set bestehend aus/ bath tub solution set comprised of:			
	2x 8120ZN		2 x 8857KU0-8-2010
	2 x 8122ZN		1 x 8863KU0-8-2010
	2 x 8124ZN		
	1 x 8861KU0-8-2010		

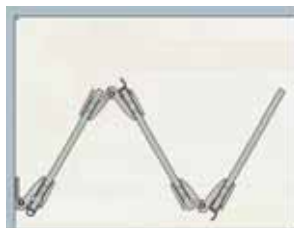

Die maximale Größe der Badewannenfaltwand beträgt 1400mm x 1600mm.
Die Scheiben tragen im gefaltetem Zustand ca. 80 mm auf./The maximum size for the complete folding door for a bath tub is 1400mm x 1600mm. The panes measure when folded, approximately 80mm from the wall.

10

8124 - 180°

