

BILOBA

8911

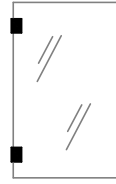

Tools Required
Strumenti Richiesti
Benötigtes Werkzeug

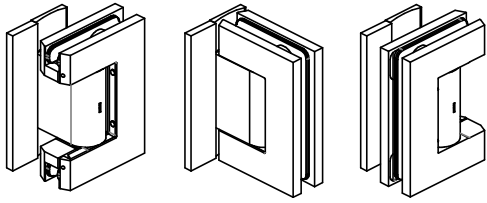
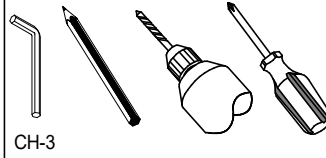

Fittings required
Fissaggi richiesti
Benötigtes Befestigungsmaterial



CH-3

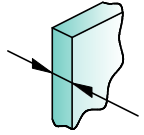

8 ÷ 13.52

GLASS
VETRO
GLAS

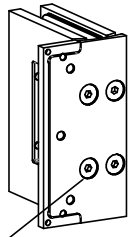

Queste viti sono serrate a 10Nm dalla fabbrica, e' vietato svitarle o allentarle

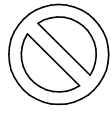

These screws are tightened at 10 Nm from the factory, it is forbidden to unscrew or loosen them

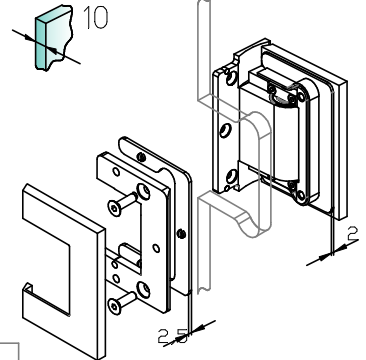
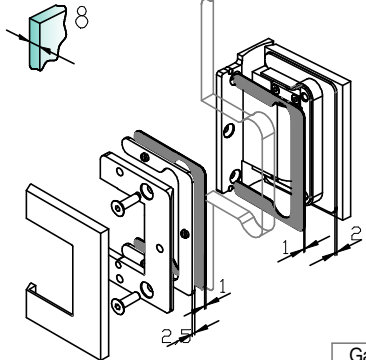

Gasket
Guarnizioni
Zwischenlagen

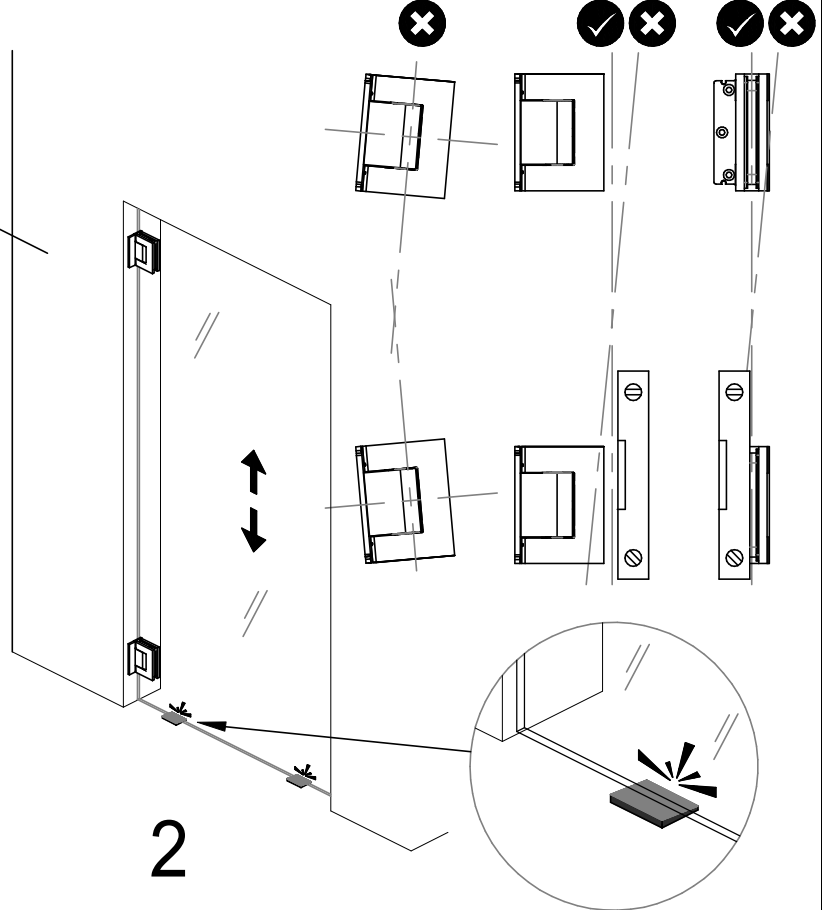
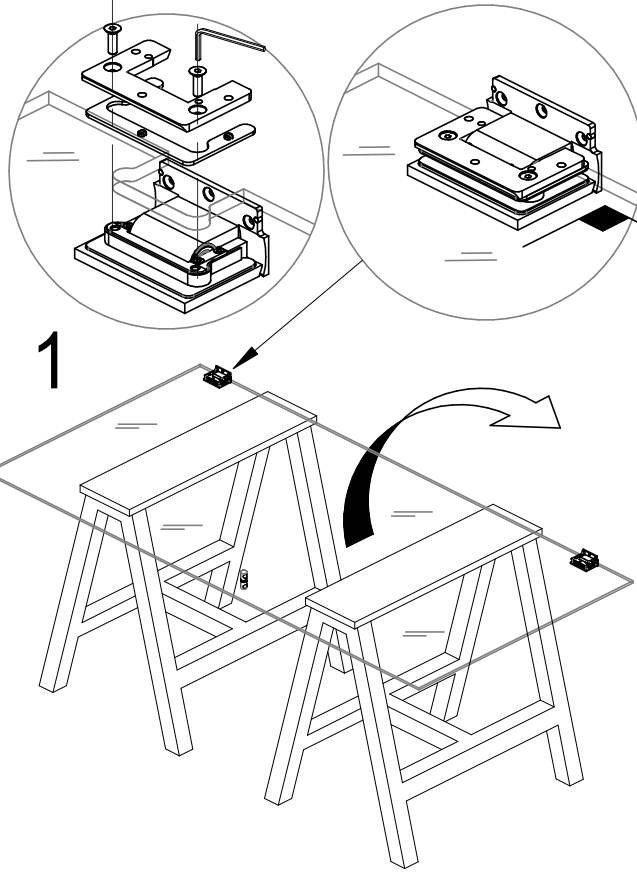
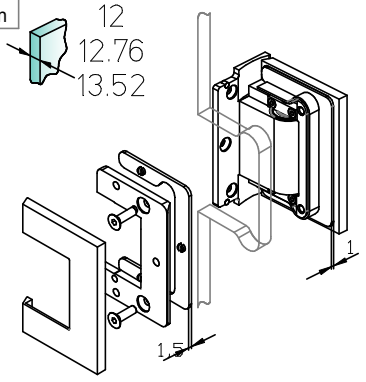
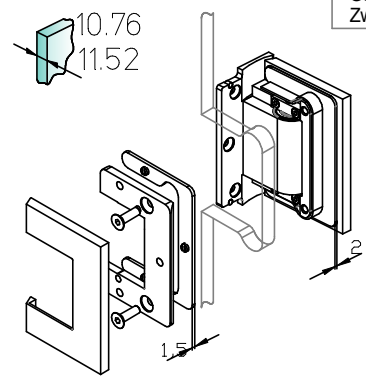

3

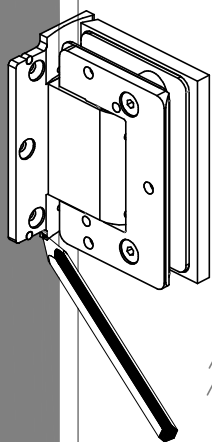

4

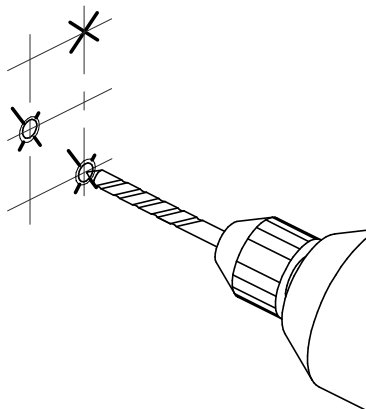

5

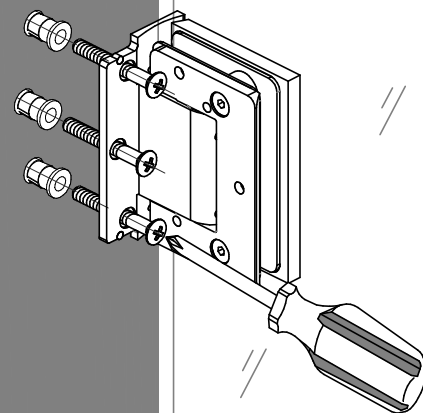

6

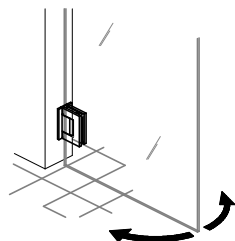

ZERO SETTING TIGHTENING ORDER FOR BOTH HINGES

- 1) Tighten the screw 'a' with tightening torque 2Nm
- 2) Tighten the screw 'b' with tightening torque 2Nm
- 3) Repeat for the second hinge
- 4) Clamp the screw 'a' with tightening torque 5Nm
- 5) Clamp the screw 'b' with tightening torque 5Nm
- 6) Repeat for the second hinge

REGOLAZIONE DEL PUNTO DI CHIUSURA

ORDINE DI SERRAGGIO PER ENTRAMBE LE CERNIERE:

- 1) Avvitare il vite "a" con una coppia di serraggio di 2Nm
- 2) Avvitare il vite "b" con una coppia di serraggio di 2Nm
- 3) Ripetere per la seconda cerniera
- 4) Serrare la vite "a" con una coppia di serraggio di 5Nm
- 5) Serrare la vite "b" con una coppia di serraggio di 5Nm
- 6) Ripetere per la seconda cerniera

NULLSTELLUNG

ANZUGSREIHENFOLGE FÜR BEIDE BÄNDER

- 1) Ziehen Sie die Schraube 'a' mit einem Drehmoment von 2Nm an
- 2) Ziehen Sie die Schraube 'b' mit einem Drehmoment von 2Nm an
- 3) Wiederholen Sie den Vorgang für das zweite Band
- 4) Ziehen Sie die Schraube 'a' mit einem Drehmoment von 5Nm an
- 5) Ziehen Sie die Schraube 'b' mit einem Drehmoment von 5Nm an
- 6) Wiederholen Sie den Vorgang für das zweite Band

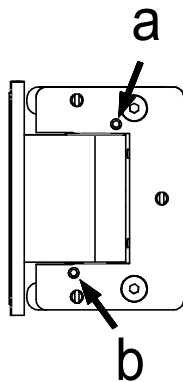

7a

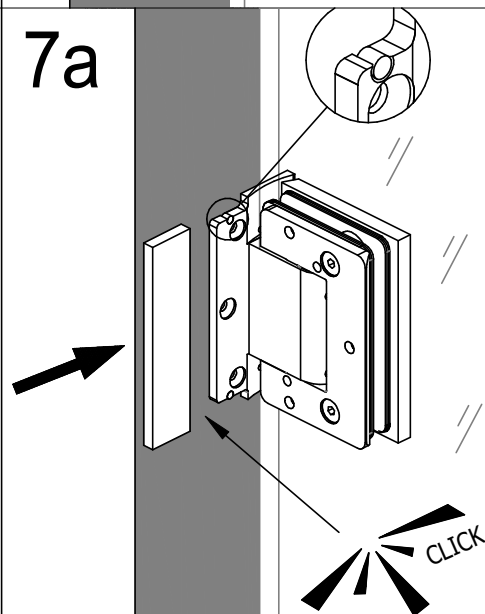

7b

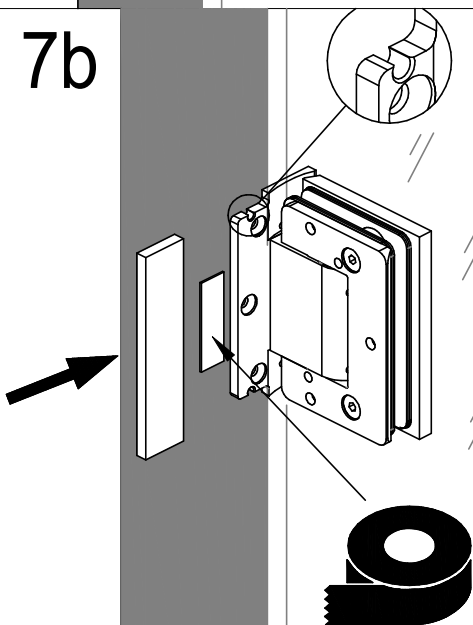

8

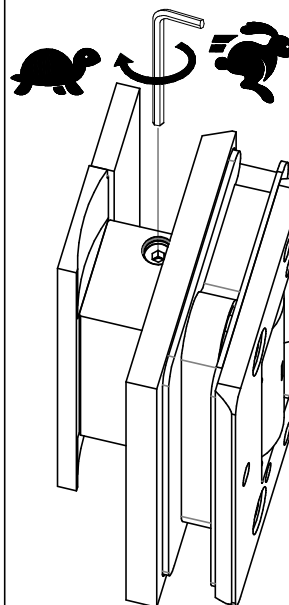
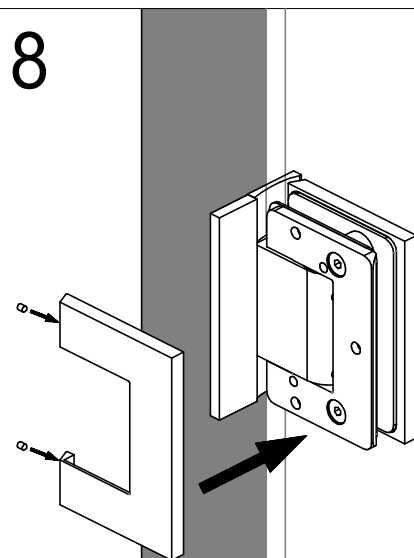

CLOSING SPEED
ADJUSTING
REGOLAZIONE TEMPO DI
CHIUSURA
EINSTELLUNG
SCHLIEßGESCHWINDIGKEIT

Non per la versione SOL
Not for SOL version
Nicht für SOL version

COLCOM®

