



**CATALOGO**

**2022**



colcomgroup.it  
seguci su    

webuildtheinvisible.com  
seguci su    

serrature / locks



Selezione di serrature disponibili con controserratura abbinata. Design pulito ed essenziale per completare l'installazione di porte in vetro a battente o libere, personalizzandole in diverse finiture.

Selection of locks with their strike boxes. Clean and essential design to complete the installation of glass doors, either one-way or double-way. Available in different finishes.

Selección de cerraduras con cerraderos combinados. Diseño limpio y esencial para completar la instalación de puertas en vidrio vaivén o con tope. Disponibles en diferentes acabados.

Auswahl an Schlössern mit passendem Sicherheitsschloss erhältlich. Sauberes und essentielles Design, um die Installation von Flügeltüren oder freien Glastüren zu vervollständigen. Erhältlich in verschiedenen Oberflächen.

Sélection de serrures disponibles avec serrure de sécurité assortie. Design épuré et essentiel pour compléter l'installation de portes vitrées battantes ou libres. Disponible en différentes finitions.



# 6640

 **Porte - Doors**



- Serratura con scrocco più mandata.
- Cerradura solo llave.
- Leverless latch.
- Schloss mit Riegel und einmal Umdrehung.
- Serrure avec pêne et un tour.



Alluminio / Aluminium :  
02-05-14-15-16-17-31-RAL-62

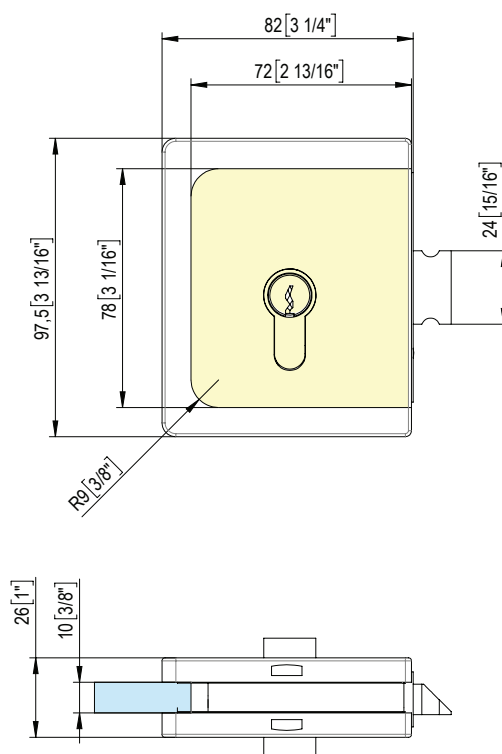
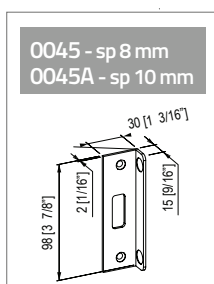
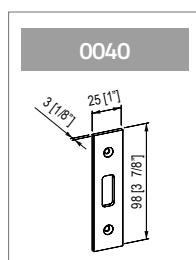

# 6641

 **Porte - Doors**



- Serratura con scrocco con foro per maniglia.
- Cerradura de pestillo con cuadro para manilla.
- Lock with latch bolt and hole for handle seating.
- Schloss mit Riegel und Loch für Türdrücker.
- Serrure avec loquet de verrou et trou pour la poignée.



Alluminio / Aluminium :  
02-05-14-15-16-17-31-RAL-62

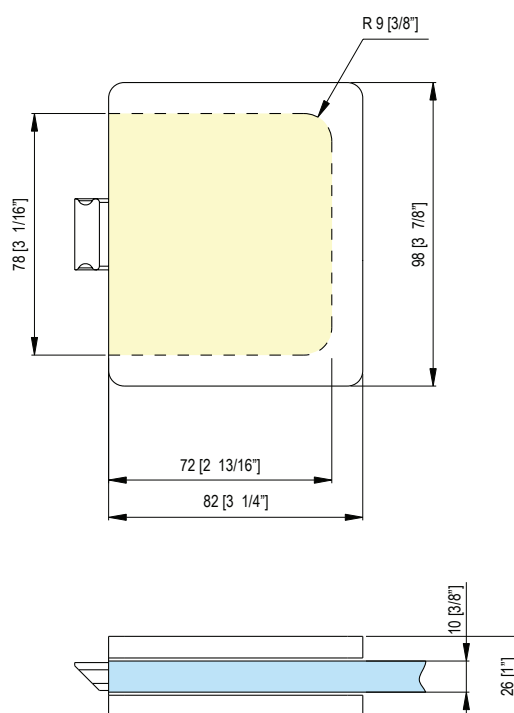
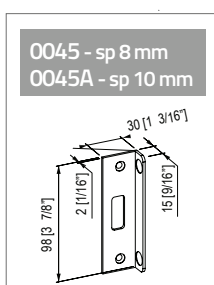
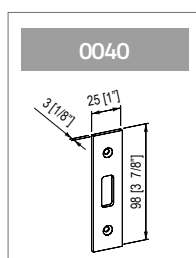

# 6645

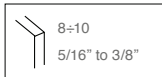

- Serratura con scrocco a rullo regolabile più mandata.
- Cerradura con pestillo de rodillo ajustable y tiro.
- Lock with adjustable barrel latch.
- Schloss mit verstellbarer Rollenverriegelung und Wurf.
- Serrure avec loquet à rouleau réglable et jet.



Alluminio / Aluminium :  
02-05-14-15-16-17-31-RAL-62

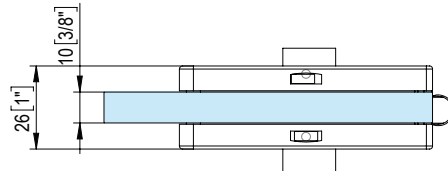
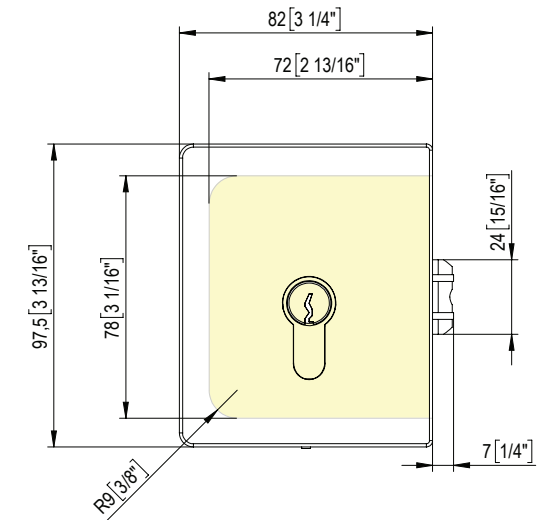
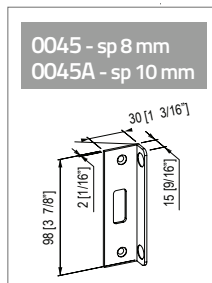
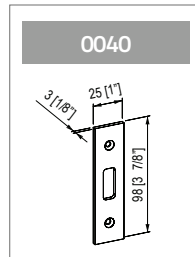

# 6840

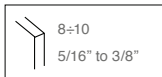

- Controserratura per art.6640-6641-6645.
- Cerradero vidrio sin tope para art. 6640-6641-6645.
- Strike box for 6640-6641-6645.
- Gegenschloss für 6640-6641-6645.
- Gâche pour art.art.6640-6641-6645.



Alluminio / Aluminium :  
02-05-14-15-16-17-31-RAL-62

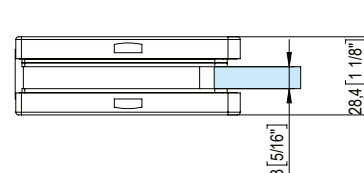
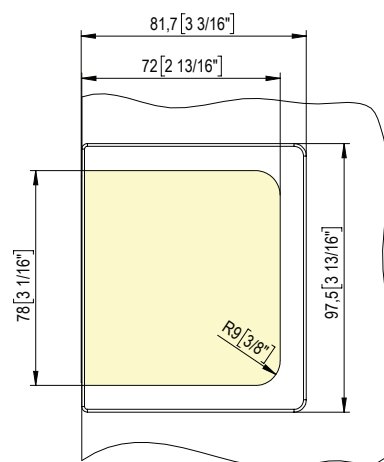

# 6845

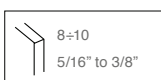

- Controserratura con battuta per art. 6640-6641-6645.
- Cerradero vidrio con tope para art. 6640-6641-6645.
- Strike box with stop for 6640-6641-6645.
- Gegenschloss mit Anschlag für 6640-6641-6645.
- Gâche en butée pour art. 6640-6641-6645.

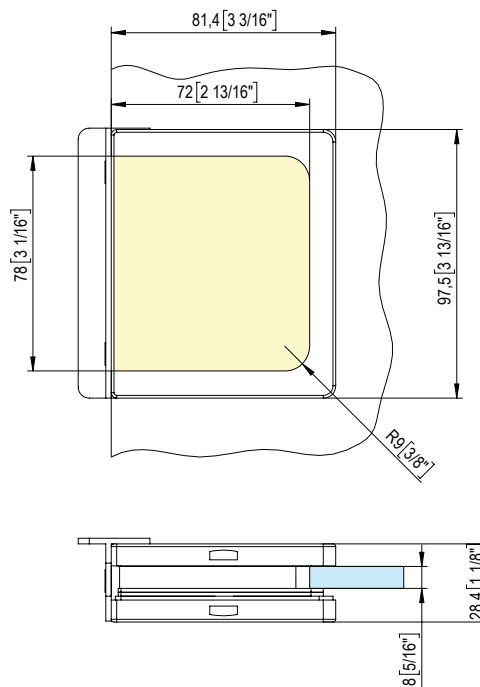

# 6870

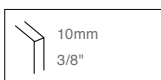

## DC 12volt

- Incontro elettrico per art. 6640.
- Cerradura eléctrica para art. 6640.
- Electric strike plate for 6640.
- Elektrisches Gegenschloss für 6640.
- Gâche électrique pour art. 6640.

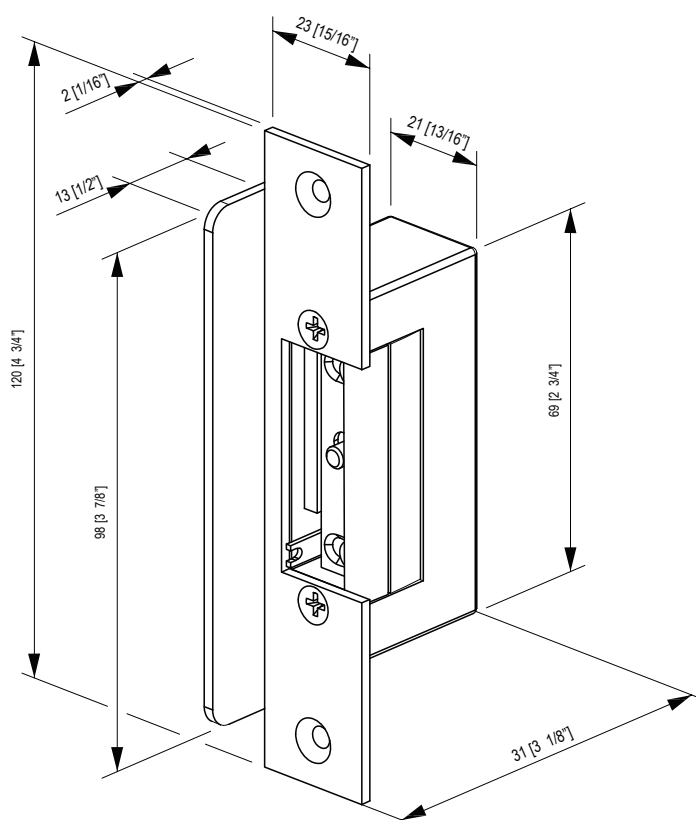

# 6875

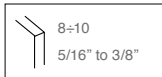

**DC 12volt**

- Controserratura elettrica per art.6640.
- Cerradero vidrio eléctrico para art. 6640.
- Electric strike box for 6640.
- Elektrisches Gegenschloss für 6640.
- Gâche électrique pour art.6640.



Alluminio / Aluminium :  
02-05-14-15-16-17-31-RAL-62

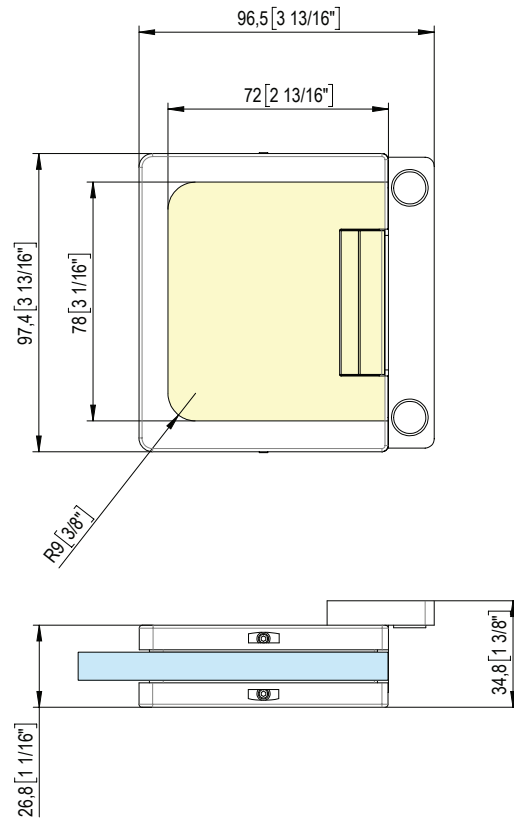

# 6040

**? SU RICHIESTA : CON MINIMO D'ORDINE!  
ON REQUEST : WITH MINIMUM QUANTITY ORDER!**



Da specificare all'ordine - Specify in the order

- Serratura con chiavistello tondo doppia mandata senza tacca nel vetro.
- Cerradura con pestillo redondo con dos vueltas sin muesca en el vidrio.
- Lock with rounded double turn dead bolt. Without cut in the glass.
- 2-fach schliessbares Schloss. Ohne Einschnitt im Glas.
- Serrure avec boulon rond à double tour sans encoche dans le verre.



Alluminio / Aluminium :  
02-05-14-15-16-17-31-RAL-62

6040-1 = destra - right    6040-2 = sinistra - left

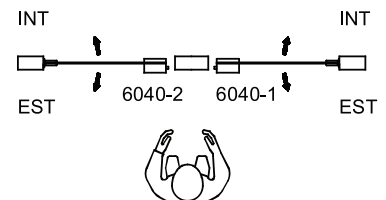
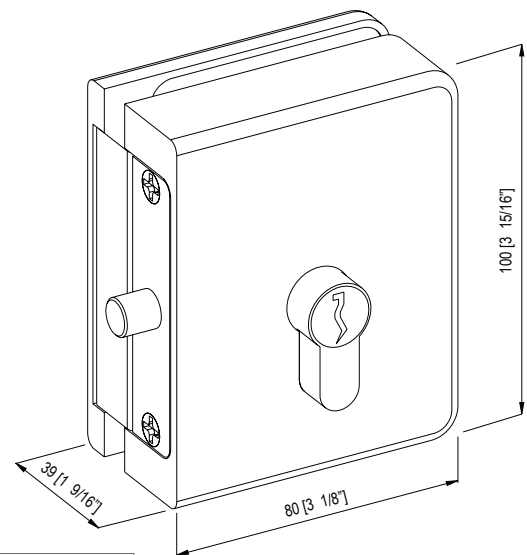
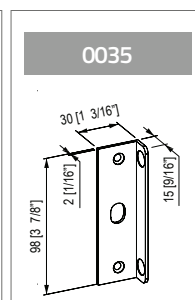
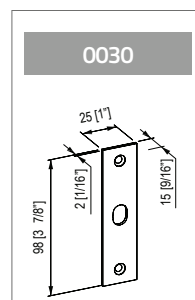
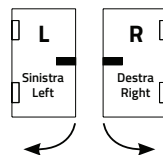

# 6050

**? SU RICHIESTA - CON MINIMO D'ORDINE!  
ON REQUEST : WITH MINIMUM QUANTITY ORDER!**



Da specificare all'ordine - Specify in the order

- Controserratura per art. 6040.
- Cerradero sin muesca en el vidrio para art. 6040.
- Strike box for 6040.
- Gegenschloss für 6040.
- Gâche pour art. 6040.



Alluminio / Aluminium :  
02-05-14-15-16-17-31-RAL-62

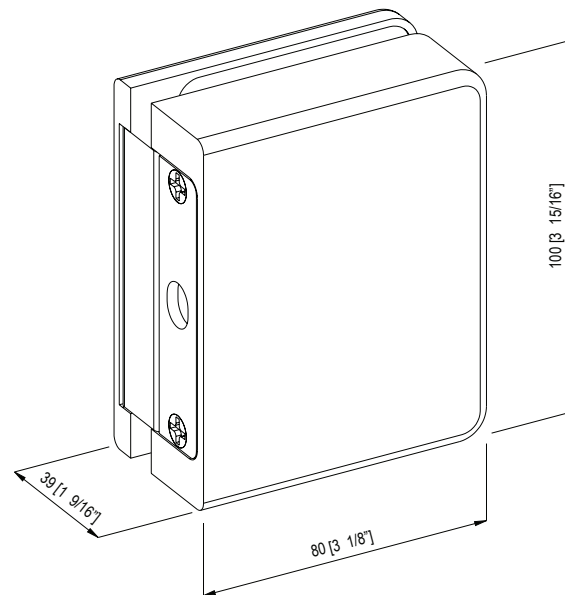

# 6630

Porte - Doors

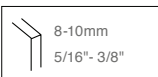

- Serratura con chiavistello tondo doppia mandata.
- Cerradura sólo llave.
- Lock with rounded double turn dead bolt.
- 2-fach schliessbares Schloss.
- Serrure avec boulon à double jet.



Ottone / Brass :  
02-05-14-15-16-17-31-RAL-62

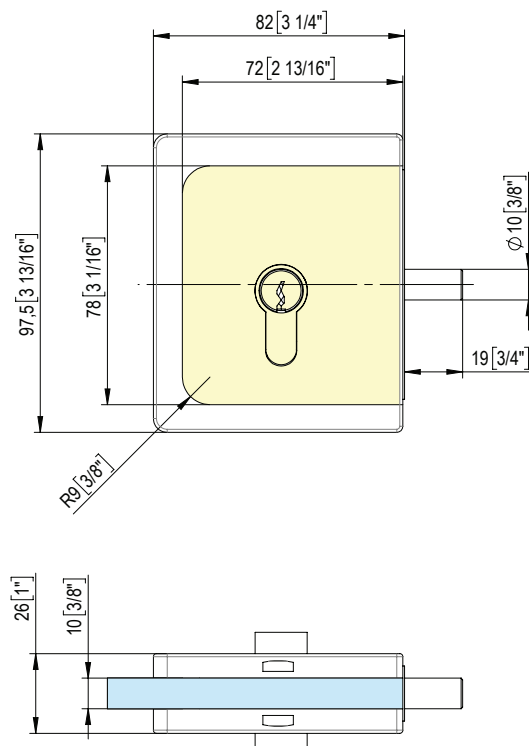
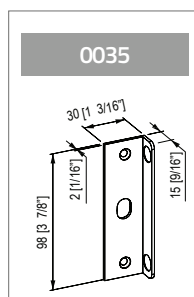
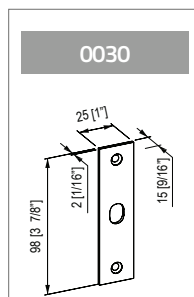

# 6830



- Controserratura per art. 6630.
- Cerradero sin tope para art. 6630.
- Strike box for 6630.
- Gegenschloss für 6630.
- Gâche pour art. 6630.

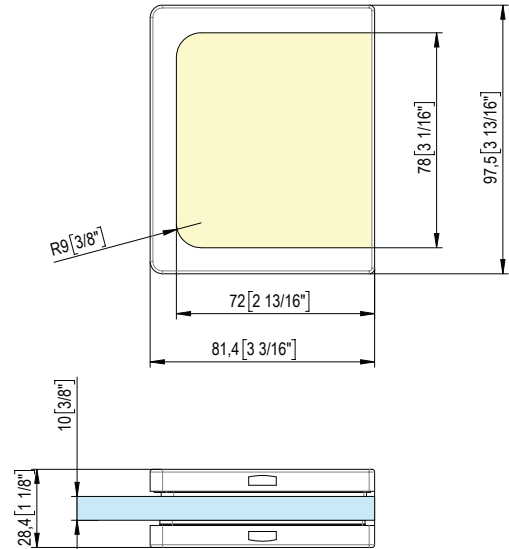

# 6835



- Controserratura con battuta per art.6630.
- Cerradero con tope, para art. 6630.
- Strike box with stop for 6630.
- Gegenschloss mit Anschlag für 6630.
- Gâche en butée pour art.6630.

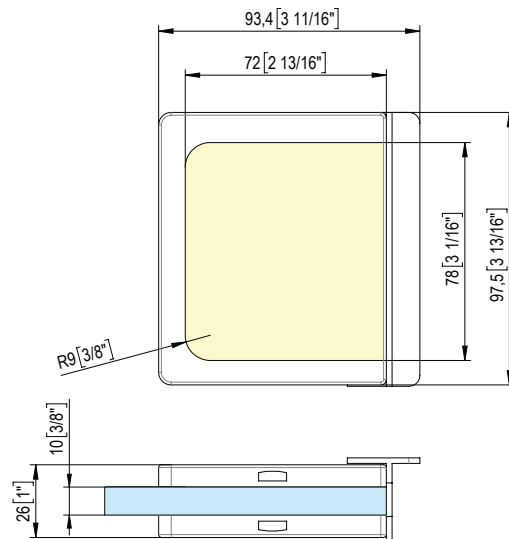



# 1030

 Porte - Doors

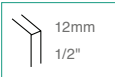
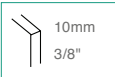

Da specificare all'ordine - Specify in the order

- Serratura stesse dimensioni della 1010 - 1020.
- Cerradura inferior: misma dimensión de 1010-1020.
- Corner lock. Same size and cut as 1010-1020.
- Schloss mit den selben Maßen von 1010-1020.
- Serrure. Mêmes dimensions et coupes que 1010 - 1020.

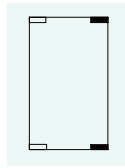

Alluminio / Aluminium : 02-05-14-15-16-17-31-RAL-62

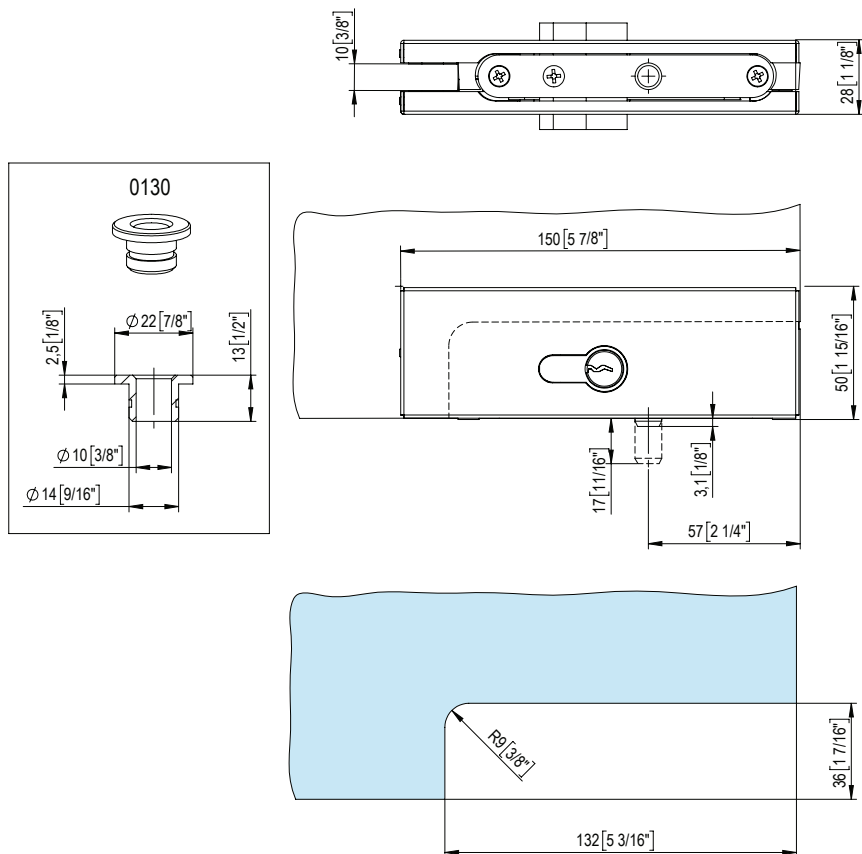

# 100E30 Biloba Unica



- Serratura stessa dimensione dell'art. 101E10 - 100E20.
- Cerradura inferior.De la misma dimension del art. 101E10 - 100E20.
- Corner lock. Same size of art. 101E10 - 100E20.
- Schloss mit den selben Maßen von 101E10 - 100E20.
- Serrure avec même dimension que l'art. 101E10 - 100E20.

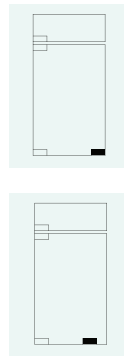



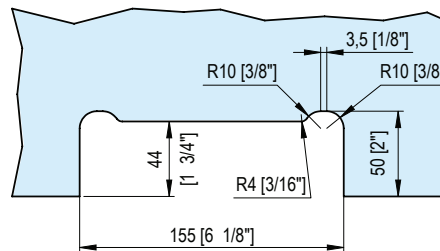
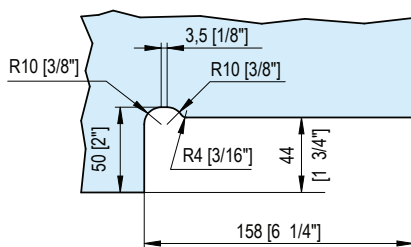
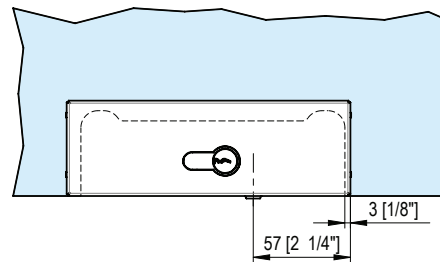
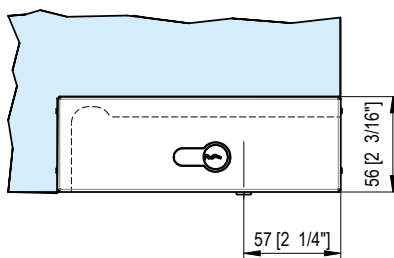
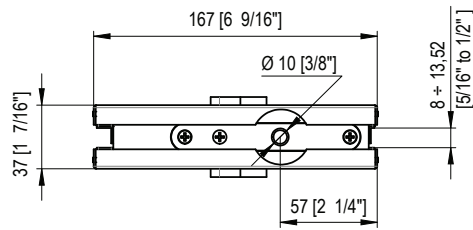
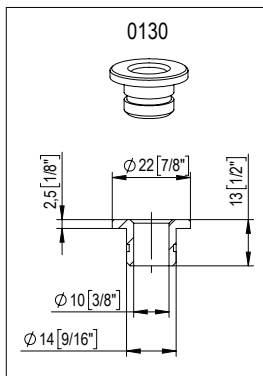



Alluminio / Aluminium : 02-05-14-15-16-17-31-32-60-62

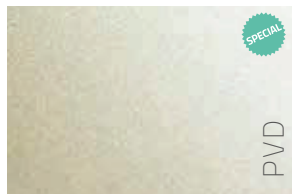

### Finiture standard / Standard finishes

|   |   |  |   |
|---|---|--|---|
|    |    |    |    |
| <b>02</b> Naturale<br>Satin anodized  | <b>05</b> Nero<br>Black   | <b>*13</b> Simil inox satinato<br>Imitation satin stainless steel                    | <b>14</b> Cromato lucido<br>Polished Chrome   |
|    |    |    |    |
| <b>15</b> Cromato opaco<br>Matt Chrome  | <b>*16</b> Oro lucido<br>Imitation Polished Gold                                    | <b>*17</b> Oro opaco<br>Imitation Matt Gold  | <b>22</b> Naturale 20 micron<br>Anodized 20 microni                                   |
|   |   |   |   |
| <b>31</b> Acciaio inox satinato<br>Satin Stainless Steel                            | <b>32</b> Acciaio inox lucido<br>Polished Stainless Steel                           | <b>47</b> Brillantato<br>Fine-polishing finish                                       |   |
|  |  |  |  |
| <b>62</b> Verniciato liquido elettrostatico<br>Liquid electrostatic coated          | Verniciato liquido elettrostatico<br>Liquid electrostatic coated                    | Verniciato liquido elettrostatico<br>Liquid electrostatic coated                     | Verniciato liquido elettrostatico<br>Liquid electrostatic coated                      |

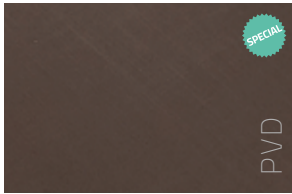
### Finiture speciali / Special finishes

|   |   |  |   |
|---|---|--|---|
|  |  |  |  |
| <b>*66</b> Bronzato lucido<br>Polished bright bronze                                | <b>*67</b> Bronzato opaco<br>Satin mat bronze                                       | <b>*68</b> Champagne lucido<br>Polished bright champagne                             | <b>*69</b> Champagne opaco<br>Satin mat champagne                                     |
|  |  |  |   |
| <b>*70</b> Nero canna di fucile lucido<br>Polished bright gunmetal grey             | <b>*71</b> Nero canna di fucile opaco<br>Satin mat gunmetal grey                    | <b>RAL</b> Verniciato liquido elettrostatico<br>Liquid electrostatic coated          |   |

**\* PVD Physical Vapour Deposition** rivestimento metallico che assicura: • eccezionale resistenza all'abrasione • resistenza all'ossidazione • colorazioni innovative ed inalterabili nel tempo.  
metal coating that ensures: • exceptional resistance to abrasion • resistance to oxidation • innovative and durable colouring.

**SPECIALI - SPECIAL** Contattare ufficio commerciale per lotti minimi, quotazione e tempi di consegna - Ask our sales dept for minimum order, for a quotation and delivery time

## Guida alla scelta della finitura / Guide to choose the colors

| Finiture / Colors    | Interno / Internal |            |       |                             |            |       |                        |            |       | Esterno / External                           |            |       |   |            |       |
|----------------------|--------------------|------------|-------|-----------------------------|------------|-------|------------------------|------------|-------|--|------------|-------|---|------------|-------|
|                      | Porte - Doors      |            |       | Box doccia - Shower Boxes   |            |       |                        |            |       | Condizioni standard<br>Standard environments |            |       | *<br>Condizioni particolari<br>Special environments |            |       |
|                      |                    |            |       | AMBIENTE BAGNATO / WET AREA |            |       | AMBIENTE UMIDO / HUMID |            |       |  |            |       |   |            |       |
| Materiale / Material | AL / ALU           | OT / BRASS | ZAMAK | AL / ALU                    | OT / BRASS | ZAMAK | AL / ALU               | OT / BRASS | ZAMAK | AL / ALU                                     | OT / BRASS | ZAMAK | AL / ALU  | OT / BRASS | ZAMAK |
| 02                   | 4                  |            |       | 4                           |            |       | 4                      |            |       | 4  |            |       | 4   |            |       |
| 05                   | 4                  |            |       | 4                           |            |       | 4                      |            |       | 4  |            |       | 4   |            |       |
| 13                   | 4                  | 4          | 4     | 2                           | 4          | 4     | 3                      | 4          | 4     | 2  | 4          | 4     |   |            |       |
| 14                   | 4                  | 5          | 4     | 3                           | 5          | 4     | 4                      | 5          | 4     | 3  | 5          | 4     |   | 5          | 4     |
| 15                   | 4                  | 5          | 4     | 3                           | 5          | 4     | 4                      | 5          | 4     | 3  | 5          | 4     |   | 5          | 4     |
| 16                   | 4                  | 4          |       | 2                           | 4          |       | 3                      | 4          |       | 2  | 4          |       |   |            |       |
| 17                   | 4                  | 4          |       | 2                           | 4          |       | 3                      | 4          |       | 2  | 4          |       |   |            |       |
| 22                   | 5                  |            |       | 5                           |            |       | 5                      |            |       | 5  |            |       | 5   |            |       |
| 31                   | 5                  |            |       | 5                           |            |       | 5                      |            |       | 5  |            |       | 5   |            |       |
| 32                   | 5                  |            |       | 5                           |            |       | 5                      |            |       | 5  |            |       | 5   |            |       |
| 47                   | 4                  |            |       | 4                           |            |       | 5                      |            |       | 4  |            |       | 4   |            |       |
| 62                   | 4                  | 4          | 4     | 4                           | 4          | 4     | 4                      | 4          | 4     | 4  | 4          | 4     | 4   | 4          | 4     |
| 66                   | 4                  | 4          |       | 2                           | 4          |       | 3                      | 4          |       | 2  | 4          |       |   |            |       |
| 67                   | 4                  | 4          |       | 2                           | 4          |       | 3                      | 4          |       | 2  | 4          |       |   |            |       |
| 68                   | 4                  | 4          |       | 2                           | 4          |       | 3                      | 4          |       | 2  | 4          |       |   |            |       |
| 69                   | 4                  | 4          |       | 2                           | 4          |       | 3                      | 4          |       | 2  | 4          |       |   |            |       |
| 70                   | 4                  | 4          |       | 2                           | 4          |       | 3                      | 4          |       | 2  | 4          |       |   |            |       |
| 71                   | 4                  | 4          |       | 2                           | 4          |       | 3                      | 4          |       | 2  | 4          |       |   |            |       |
| RAL                  | 4                  | 4          | 4     | 4                           | 4          | 4     | 4                      | 4          | 4     | 4  | 4          | 4     | 4   | 4          | 4     |

\* **ATTENZIONE:** Per installazioni in condizioni ambientali e climatiche particolari (es. umide, acide, saline), consultare prima l'ufficio commerciale  
**CAUTION:** For installations in particular environments or climate (ex. wet, acid, saline) consult sales office first

**PORTE ESTERNE - OUTER DOORS:** Le finiture disponibili sono / The finishes available are : 22 - 31 - 32 - RAL - 62  
 Finiture NON RACCOMANDATE sono / NOT RECOMMEND finishes are : 02 - 05 - 13 - 14 - 15 - 16 - 17 - 47

## Legenda / Legend

| 1  | 2  | 3  | 4   | 5   |
|--|--|--|---|---|
| Bassa resistenza alla corrosione<br>Low corrosion resistance | Moderata resistenza alla corrosione<br>Moderate corrosion resistance | Alta resistenza alla corrosione<br>High corrosion resistance | Resistenza molto alta alla corrosione<br>Very high corrosion resistance | Resistenza eccellente alla corrosione<br>Excellent corrosion resistance |

Tutti i patch fitting con corpo in finitura "22" e copertine di acciaio inox hanno grado di resistenza pari a 5. In caso di copertine in alluminio la resistenza è indicata nella tabella sovrariportata  
 All patch fittings with body in "22" finish and stainless steel covers have a strength of 5. In the case of aluminum covers the resistance is indicated in the table above

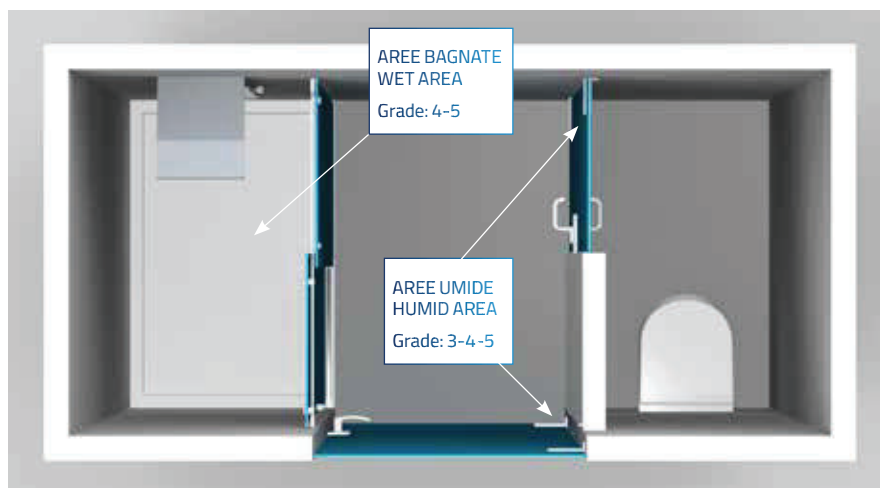

## AREE BAGNATE / WET AREA

Spazi a contatto diretto con l'acqua  
Spaces in direct contact with water

## AREE UMIDE / HUMID AREA

Spazi non a contatto diretto con l'acqua ma umidi  
Spaces not in direct contact with water but humid

Nuove impostazioni / New settings



**Box doccia - Shower boxes**

cerniere, sistemi e accessori  
hinges, systems and complements



**Porte - Doors**

cerniere, scorrevoli e accessori  
hinges, sliding and complements



**Partizioni - Partitioning**

sistemi profili, morsetti, balaustre e pensiline  
system profile, clamps, balustrade and canopies

CATALOGO CATALOGUE COLCOM

tipologia - typology

cerniere oleodinamiche / oildynamic hinges

**Biloba BT**

serie - serie

8010BT

8011BT

8015BT

8060BT

caratteristiche principali  
main features

Alluminio / Aluminium - finiture / colors 05-13-14-15-16-17-22-RAL-62

Cerniere oleodinamiche nate per l'applicazione in ambienti umidi come box doccia, saune e bagni turchi. Dotate di tutte le caratteristiche che contraddi-

CATALOGO CATALOGUE COLCOM

serie - serie tipologia - typology

peso massimo supportato da 2 cerniere  
maximum weight supported by 2 hinges categoria prodotto  
product category

**835E10N Biloba EVO** colcom OILDYNAMIC 120 Kg - 264 lbs Porte - Doors

codice articolo  
item number

caratteristiche  
features

|                          |                                |                            |                    |
|--------------------------|--------------------------------|----------------------------|--------------------|
| 8÷21,52<br>5/16" to 7/8" | 800÷1200mm<br>31.49" to 47.24" | -15°C +5°F<br>+40°C +104°F | 80° 90°<br>0° 180° |
|--------------------------|--------------------------------|----------------------------|--------------------|

- Cerniera oleodinamica vetro-muro per porte in battuta, con velocità di chiusura regolabile e controllo costante di frenatura; permette un'apertura della porta fino a 180°. Stop a +90° +180°. Si installa su porte con profilo in battuta. Profondità stipite da 30 a 50 mm.
- Bisagra automática hidráulica vidrio-pared para puerta con tope; regulación de velocidad de cierre de la puerta y control constante de frenado; la puerta se puede abrir hasta 180°. Stop a +90° +180°. Se instala en puertas con perfil con batida. Profundidad estípites entre 30 y 50 mm.
- Hydraulic hinge glass to wall for doors with stop, with adjustable closing speed and constant braking control; the door opens up to 180°. Stop at +90° +180°. Installed on doors with a profile on a stop. Jamb depth from 30 to 50 mm.
- Hydraulikband Glas-Wand für Anschlagtüren, mit regulierbarer Schließgeschwindigkeit und konstanter Kontrolle der Bremsung; Öffnung der Tür bis 180°. Feststellung +90° +180°. Man kann es auf Türen mit Rahmen benutzen. Pfostentiefe von 30 bis 50 mm.
- Charnière hydraulique verre-mur pour porte à butée avec contrôle constant de la vitesse de fermeture : fermeture, ce qui permet une ouverture de la porte jusqu'à 180°. Arrêt à +90° et +180°. S'installe sur profil de porte. Profondeur du jambage de 30 à 50 mm.

note e informazioni - notes and information

Per installazioni in condizioni ambientali e climatiche particolari (es. Umide, acide, saline), consultare prima l'ufficio commerciale  
For installations in particular environments or climate (ex. Wet, acid, saline) consult sales office first

materiale e finiture  
material and finishes

Alluminio / Aluminium : 02-05-13-14-15-16-17-22-RAL-62

avvertenze - warnings

**835E10N R = destra - right**  
**835E10N L = sinistra - left**

**È NECESSARIA UNA BATTUTA IN CHIUSURA IN QUANTO LA CERNIERA HA UNA PRECARICA. THEREFORE NECESSARY A CLOSING STOP**

## Legenda simboli / Symbol legend

▪ categoria prodotto / product category :



**Box doccia**  
Shower boxes



**Porte**  
Doors



**Partizioni**  
Partitioning

▪ tipologia articolo / item typology :



**Articolo oleodinamico**  
Hydraulic item



**Cerniera automatica**  
Automatic hinge



**Cerniera a scatto**  
Clicking hinge



**Cerniera libera**  
Free hinge



Articolo adatto ad ambienti interni ed esterni  
Item suitable for indoor and outer environments



Articolo adatto adatti esclusivamente per ambienti interni  
Item suitable exclusively for indoor environments

▪ caratteristiche / features :



**Sistema oleodinamico**  
Hydraulic system



**Prodotto certificato**  
Certified product



**Prodotto brevettato**  
Patented product



**Regolazione del punto 0°**  
0° point adjustability



**Spessore del vetro**  
Glass thickness



**Larghezza max porta**  
Max door width



**Temperatura di esercizio olio**  
Operating oil temperature



**Peso massimo della porta - supportato da 2 cerniere o dal sistema**  
Max door weight - supported by 2 hinges or by system

### Angolo di chiusura automatica - Automatic closing angle

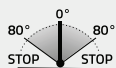

apertura / opening :  $\pm 90^\circ$   
stop da / stop from :  $\pm 90^\circ$  a/to  $\pm 80^\circ$  0°  
chiusura automatica / automatic closing :  $\pm 80^\circ$



apertura / opening :  $90^\circ$   
stop da / stop from :  $90^\circ$  a/to  $80^\circ$   
chiusura automatica / automatic closing :  $80^\circ$



apertura / opening :  $+90^\circ - 90^\circ$   
stop da / stop from :  $\pm 90^\circ$  a/to  $\pm 15^\circ$   
chiusura automatica / automatic closing :  $\pm 15^\circ$



apertura / opening :  $90^\circ$   
stop da / stop from :  $90^\circ$  a/to  $15^\circ$  0°  
chiusura automatica / automatic closing :  $15^\circ$

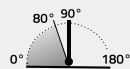

apertura / opening :  $180^\circ$   
stop da / stop from :  $180^\circ$  a/to  $80^\circ$   
chiusura automatica / automatic closing :  $80^\circ$



apertura / opening :  $180^\circ$   
stop da / stop from :  $180^\circ$  a/to  $160^\circ$   
chiusura automatica / automatic closing :  $160^\circ$

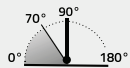

apertura / opening :  $180^\circ$   
stop da / stop from :  $180^\circ$  a/to  $70^\circ$   
chiusura automatica / automatic closing :  $70^\circ$



apertura / opening :  $\pm 90^\circ$   
stop da / stop from :  $\pm 90^\circ$  a/to  $\pm 85^\circ$  0°  
chiusura automatica / automatic closing :  $\pm 85^\circ$



apertura / opening :  $0^\circ$  a/to  $180^\circ$   
stop da / stop from : NO  
chiusura automatica / automatic closing : NO



**AVVERTENZA!** Leggere con attenzione  
**WARNING!** Read carefully



**INFORMAZIONI** - leggere attentamente  
**INFORMATION** - please read carefully



**articolo su richiesta** : con minimo d'ordine  
**item on request** : with minimum quantity order

## DIN 107 Come determinare la mano dei nostri articoli / How to determine the hand of our articles

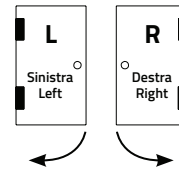
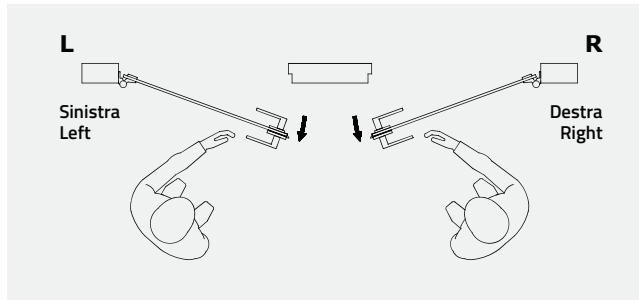

Per le cerniere disponibili nelle versioni DESTRA e SINISTRA, le schede tecniche riportano questo simbolo indicativo.

For the hinges available in the RIGHT and LEFT versions, the technical data sheets bear this indicative symbol.

Riferirsi allo schema qui sopra per determinare la mano di apertura delle porte - Refer to the diagram above to determine the opening hand of the doors

### Coppie di serraggio viti consigliate

Tightening torque for suggested screws



| DIMENSIONE VITE<br>SCREW DIMENSION<br>(Passo grosso - Coarse pitch) | COPIA DI SERRAGGIO<br>TIGHTENING TORQUE<br>Nm |
|---|---|
| M4  | 3   |
| M5  | 6   |
| M6  | 10  |

## UNI EN 1154 : 2006 Come leggere i valori della certificazione / How to read the certification values



Gli articoli OLEODINAMICI appartenenti alle famiglie: BILOBA, TRILOBA e UNICA hanno ottenuto la certificazione EN 1154  
The HYDRAULIC articles belonging to the families: BILOBA, TRILOBA and UNICA have obtained the EN 1154 certification

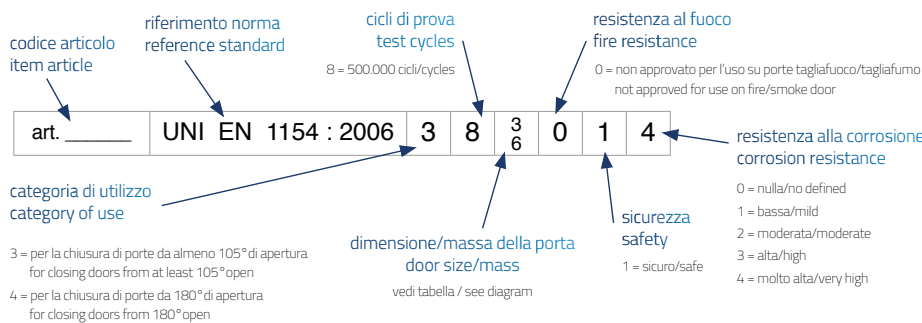

| FORZA DI CHIUSURA<br>POWER OF CLOSER | PESO PORTA<br>DOOR WEIGHT | LARGHEZZA PORTA<br>WIDTH OF DOOR |
|--------------------------------------|---------------------------|----------------------------------|
| 1                                    | 20 kg                     | < 750 mm                         |
| 2                                    | 40 kg                     | 850 mm                           |
| 3                                    | 60 kg                     | 950 mm                           |
| 4                                    | 80 kg                     | 1100 mm                          |
| 5                                    | 100 kg                    | 1250 mm                          |
| 6                                    | 120 kg                    | 1400 mm                          |
| 7                                    | 160 kg                    | 1600 mm                          |

**QRcode** Sui principali prodotti abbiamo introdotto il QR Code che riporta alle brochure di presentazione.

On the main products we have introduced the QR Code that shows to the presentation brochures.



